

2

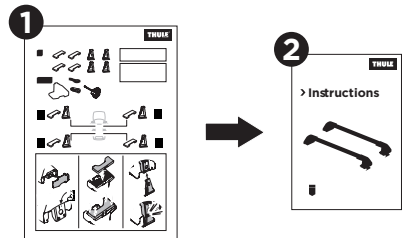

# > Instructions

Thule Edge Clamp  
720500

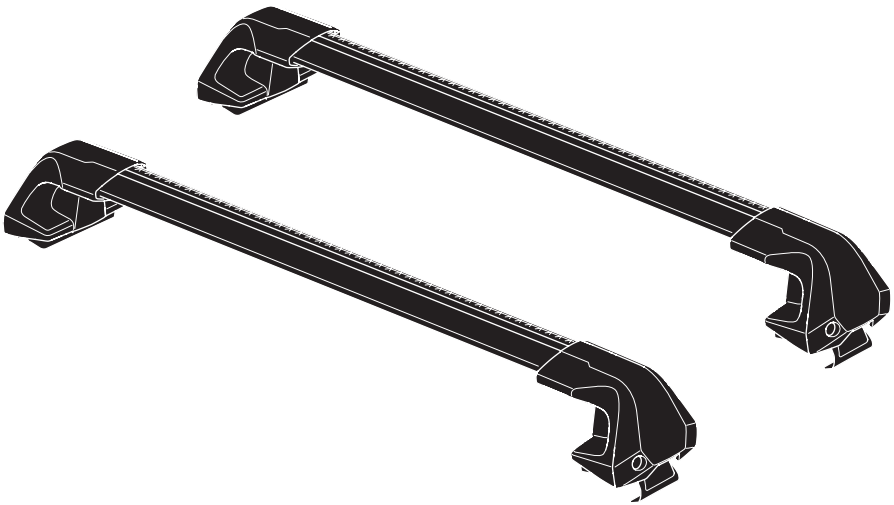

**EN** Roof mounted load carrier  
**DE** Lastenträger zur Dachmontage  
**FR** Barre de toit  
**NL** Dakdrager  
**IT** Barra portatutto da installare sul tetto  
**ES** Portaequipajes de techo  
**PT** Barra para montagem no tejadilho  
**SV** Takmonterad lasthållare  
**DK** Tagmonteret lastholder  
**NO** Takmonteret lasteholder  
**FI** Katolle asennettava teline  
**ET** Katusele paigaldatav katuseraam  
**LV** Uz jumta uzstādāms kravas turētājs  
**LT** Ant stogo tvirtinamas krovinų laikiklis  
**PL** Uchwyt na bagażnik bazowy montowany na dachu  
**RU** Багажник на крышу  
**UK** Багажник для даху  
**BG** Багажник, монтиран върху покрива  
**CS** Nosič pro montáž na střechu  
**SK** Strešný nosič  
**SL** Nosilec za strešni prtljažnik  
**HR/BIH** Krovni nosač tereta

**RO** Suport încărcătură montat pe acoperiș  
**HU** Tetőre szerelhető csomagszállító  
**EL** Σχάρα οροφής για μεταφορά φορτίου  
**TR** Araç üstüne bağlanan yük taşıyıcı  
 מנשא מטען לגג הרכב **HE**  
 حامل نقل مثبت على السقف **AR**  
**ZH** 顶置行李架  
**JA** ルーフマウント型ロードキャリア  
**KO** 루프 장착 화물 캐리어  
**TH** โครงยึดของบรรทุกแบบติดตั้งบนหลังคา

**CITY CRASH**

Complies with ISO norm

ISO 11154-E

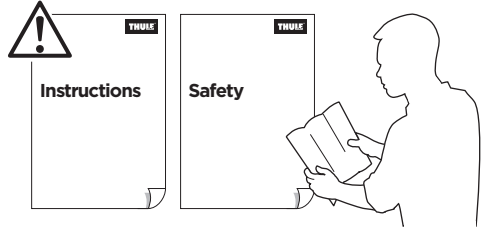

**i**

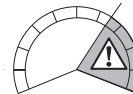

Max 130 km/h  
80 Mph

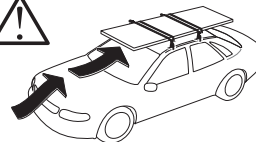
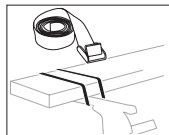
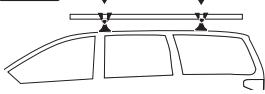

80 km/h  
50 Mph

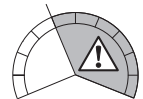

## > Mounting Tutorial

Thule Edge Clamp

**THULE**  
SWEDEN



thule.com

**1**  
KIT

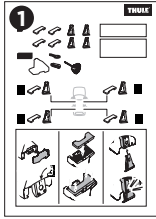

+

**2**  
FOOT PACK

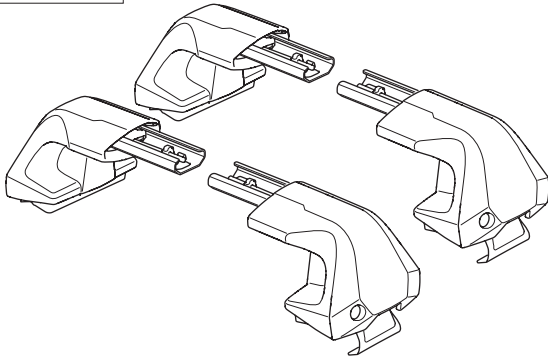

x4



x2

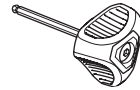

3 Nm

x1

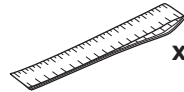

x1

BAR

**3**

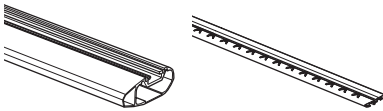

BAR

**3**

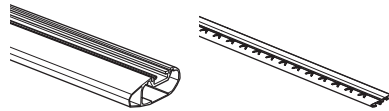



**i**

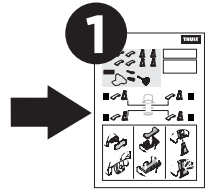
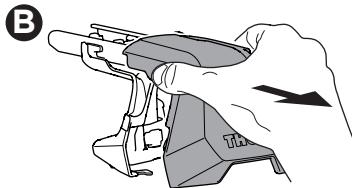
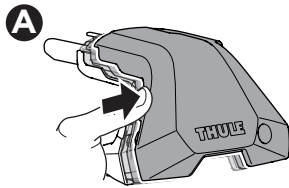
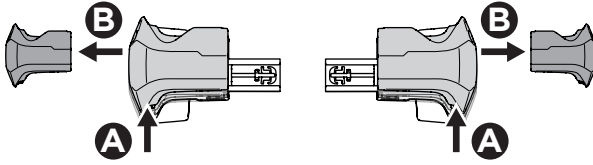

**1**

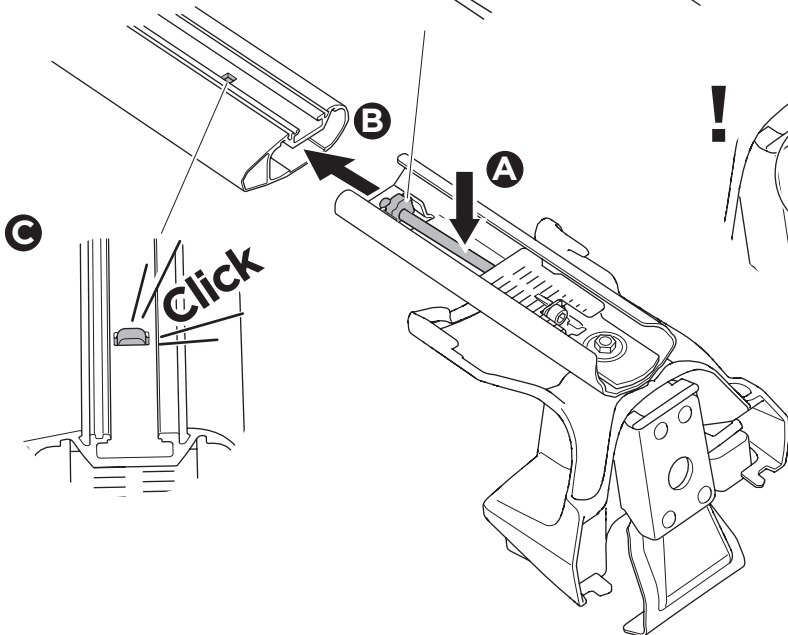
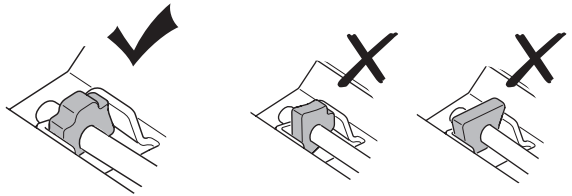

x4

# 2

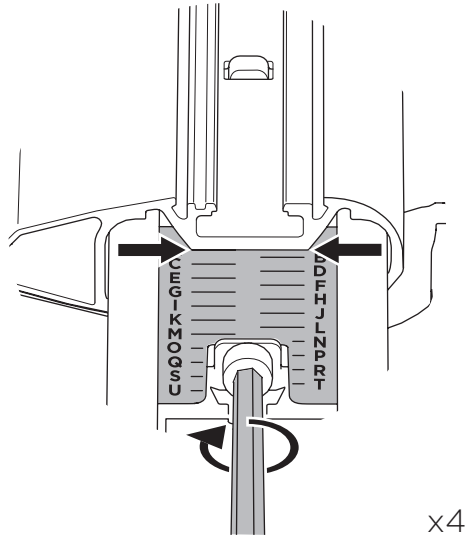
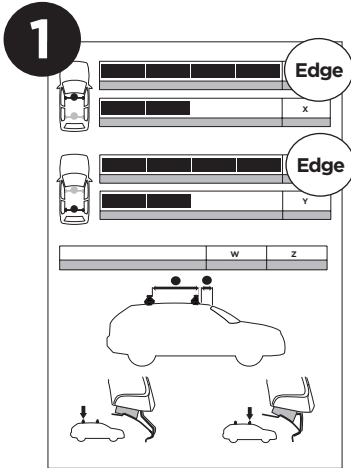
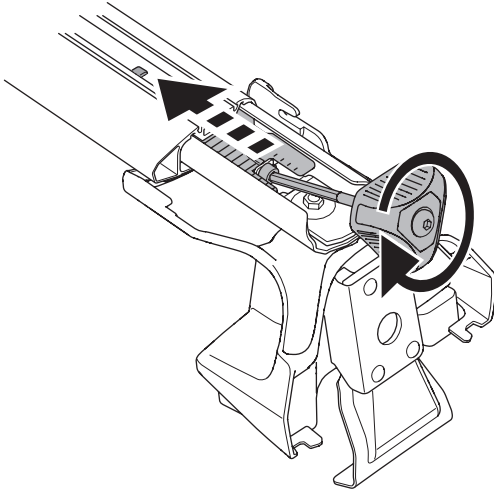

3

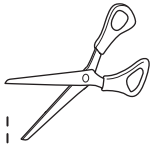

A

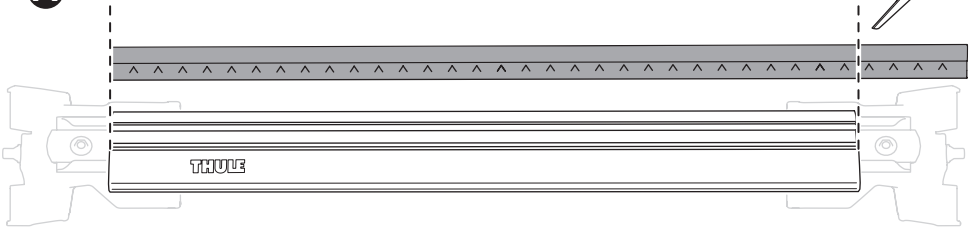

B

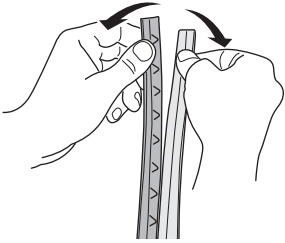

C

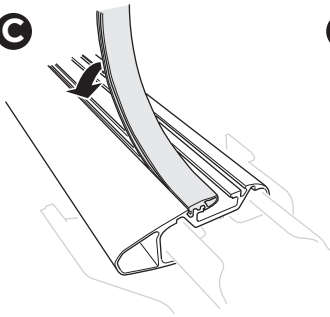

D

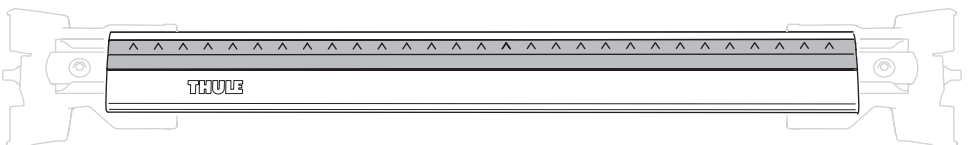
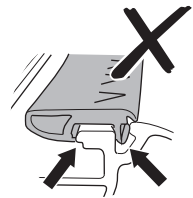
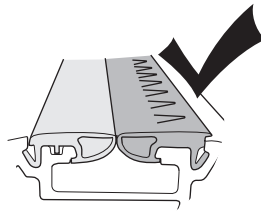
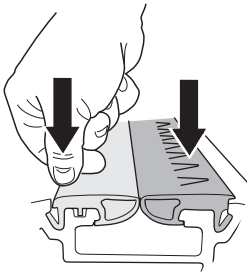
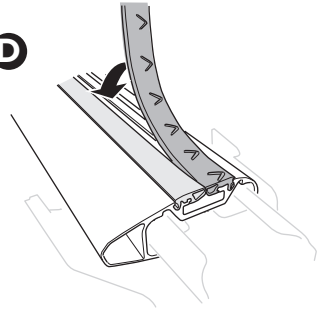

x2

# 4

**A**

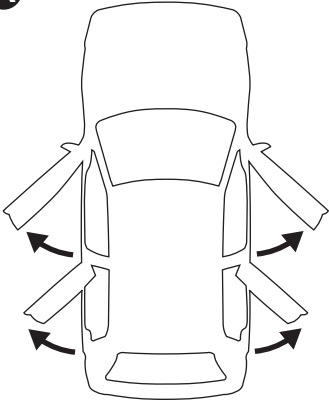

**B**

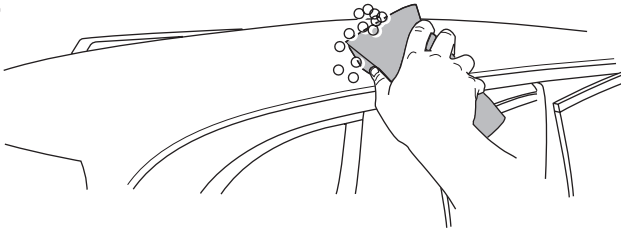

**C**

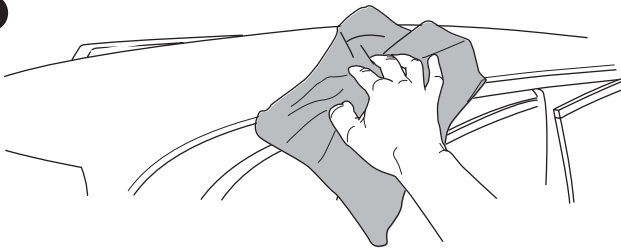

5

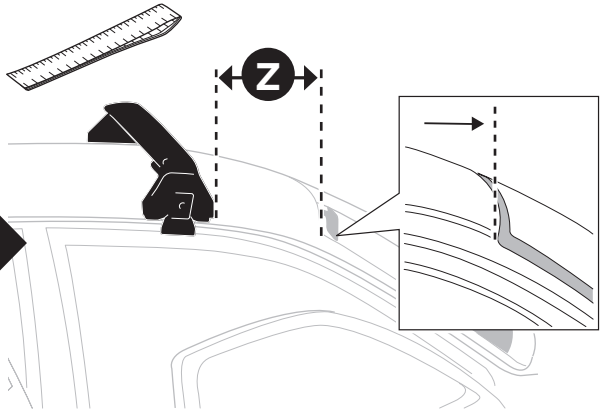
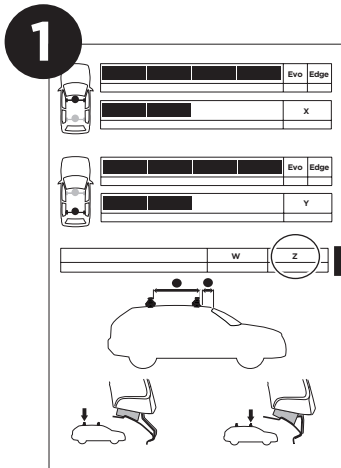
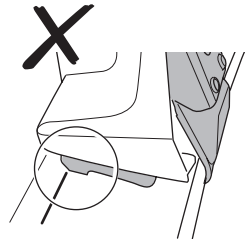
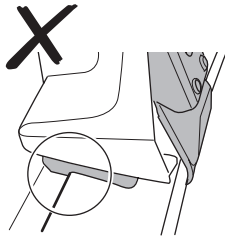
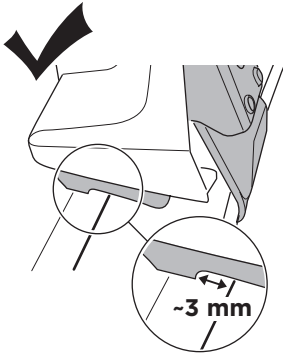
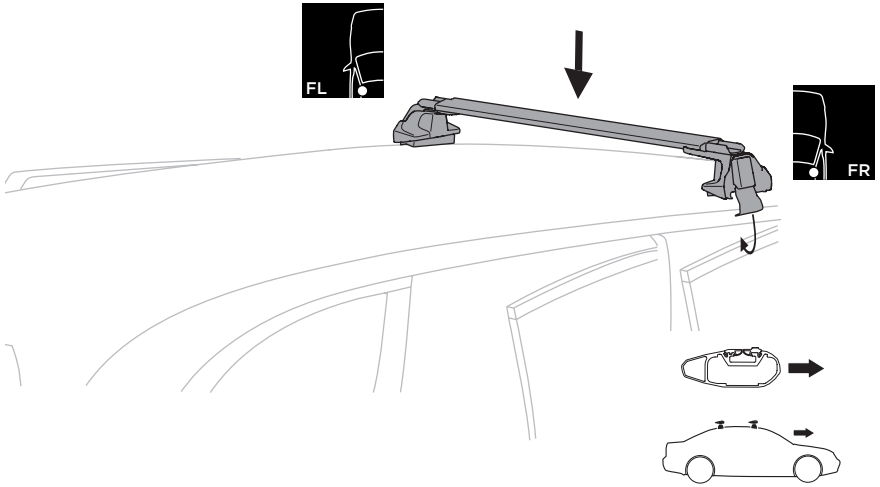



6

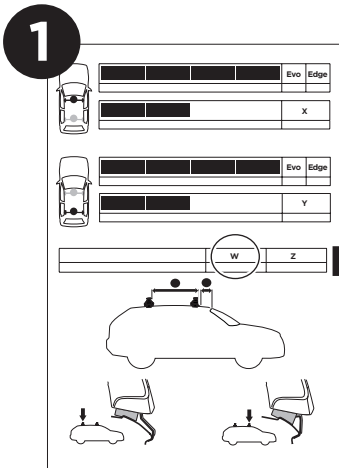
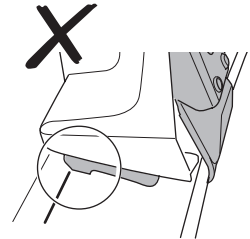
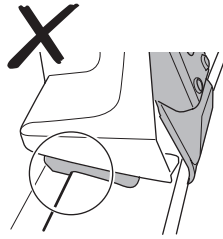
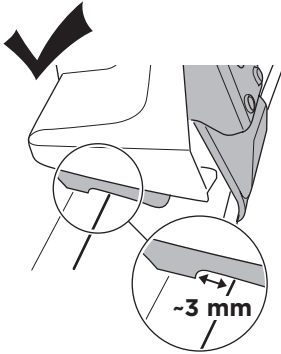
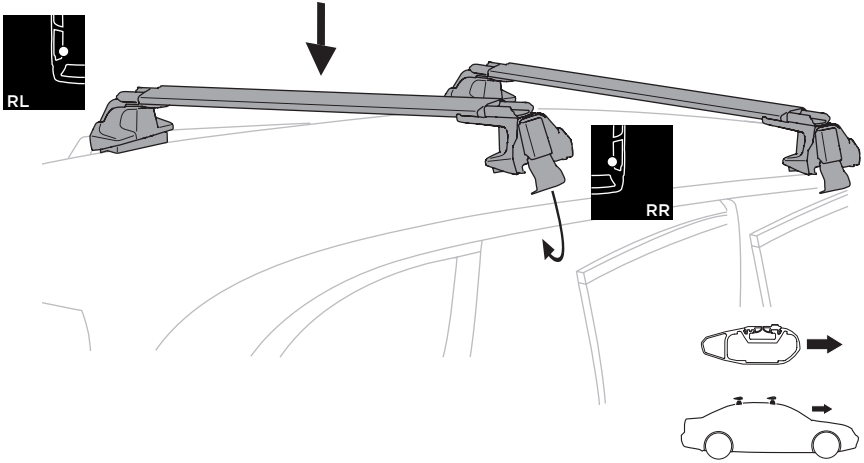

# 7

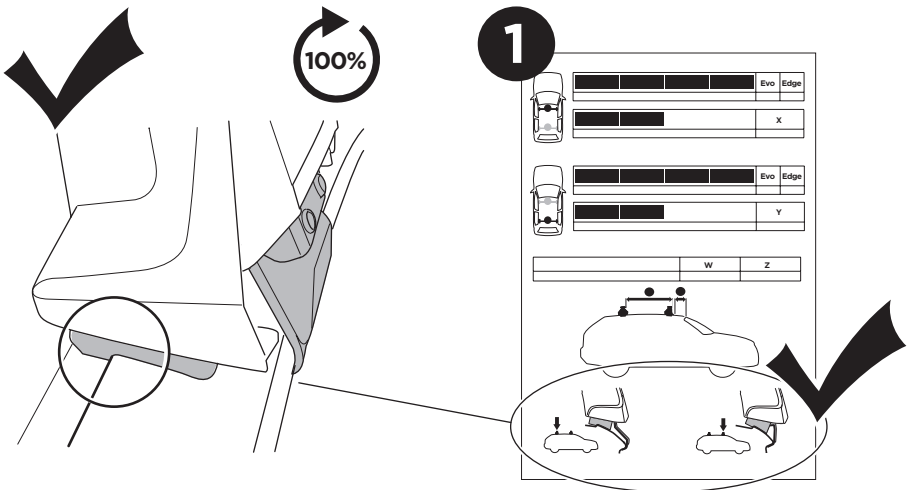
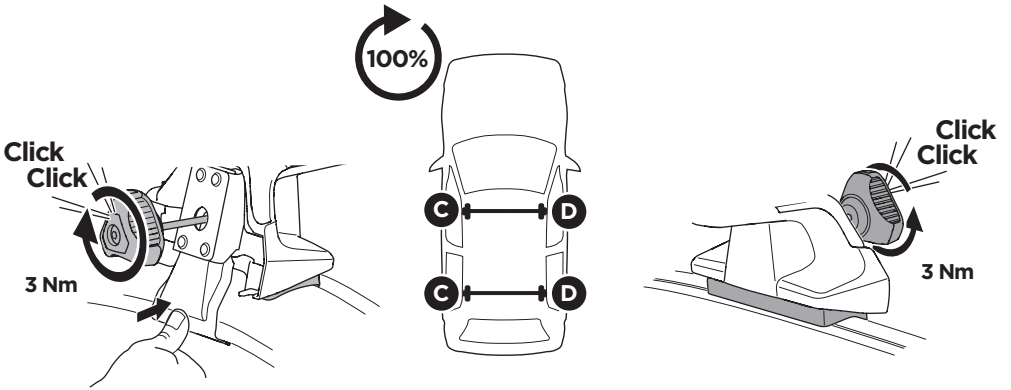
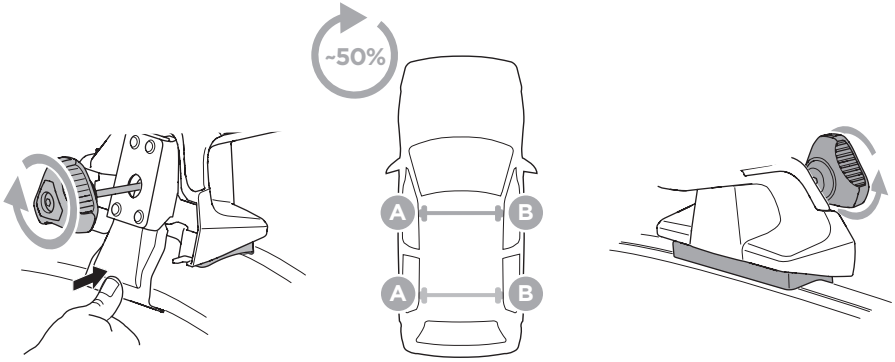

8

A

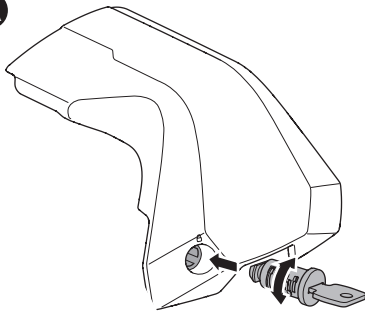

B

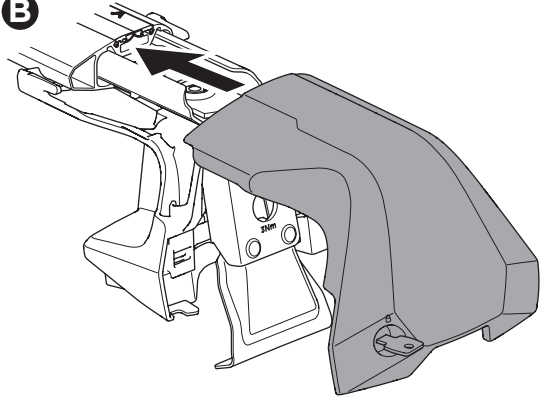

C

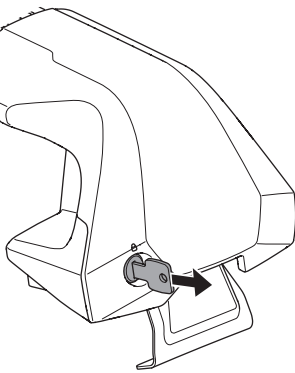
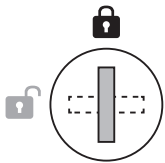

x4

9

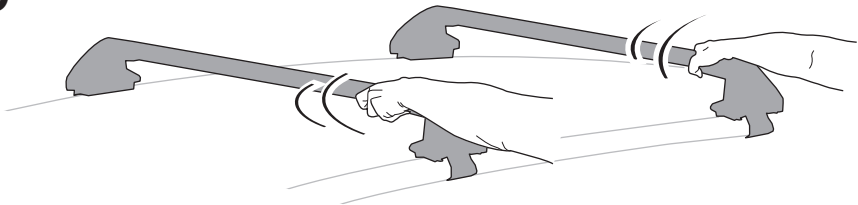

50 km



500 km

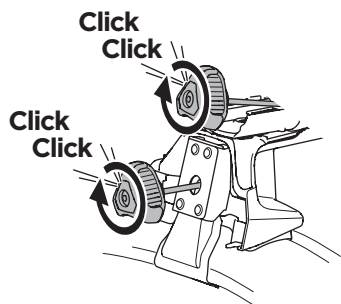

**i**

**A**

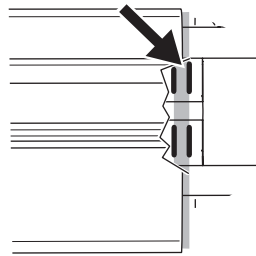
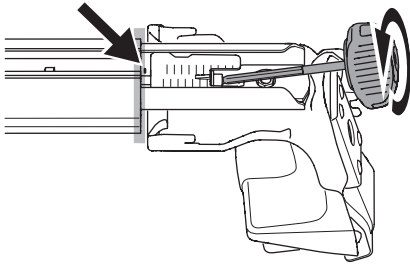

**B**

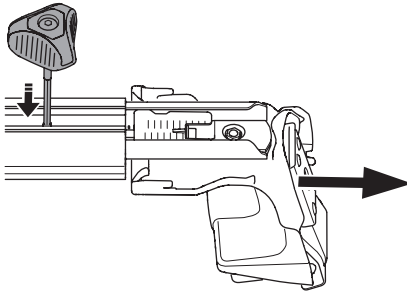

**C**

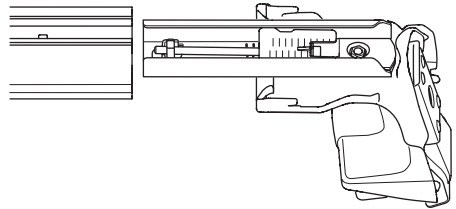

**i**

